



TORAY Membrane Module Specification Sheet

- Model: PVDF Hollow Fiber Membrane Module HFU series (type N)

Table 1. Membrane Properties

Membrane Material	PVDF (Polyvinylidene fluoride)
Nominal Molecular Weight Cut Off	150,000

Table 2. Cleaning Limits

Cleaning pH Range	0 – 12
Maximum Cleaning Temperature	40 degree C (104 degree F)
Maximum Concentration of NaClO Cleaning as Cl ₂	3,000 mg/L (10 ≤ pH ≤ 12)
Maximum NaClO Exposure (lifetime contact time) as Cl ₂	1,000,000 mg/L hours
Maximum Acid Exposure Contact Time	1,000 hours (pH ≥ 0)

Table 3. Module Specifications

Module Type		HFU-2020N	HFU-1020N	HFU-1010N (small module for pilot test)	HFU-2008N (small module for pilot test)
Membrane Surface Area (Outer Surface)		72 m ² (775 ft ²)	29 m ² (312 ft ²)	7.0 m ² (75 ft ²)	11.5 m ² (124 ft ²)
Dimensions	Diameter	216 mm (8.50 inches)	216 mm (8.50 inches)	114 mm (4.49 inches)	89 mm (3.50 inches)
	Length	2,160 mm (7.087 ft.)	1,120 mm (3.675 ft.)	1,078 mm (3.537 ft.)	2,000 mm (6.562 ft.)
Weight	Full of water	110 kg (243 lbs)	60 kg (132 lbs)	15 kg (33 lbs)	18 kg (40 lbs)
	Drained	67 kg (148 lbs)	40 kg (88 lbs)	9 kg (20 lbs)	11 kg (24 lbs)
Materials	Housing	PVC and/or ABS			
	Potting Material	Epoxy Resin or Urethane Resin			
Operating Conditions	Filtration Method	Outside to inside, dead end			
	Maximum Inlet Pressure	300 kPa (43.5 psi)			
	Maximum Trans Membrane Pressure	300 kPa (43.5 psi)			
	Typical Operating Trans-Membrane Pressure	< 200 kPa (< 29.0 psi)			
	Operating Temperature Range	0 – 40 degree C (32 – 104 degree F)			
	Operating pH Range	1 – 10			

Note) This specification sheet will be updated by TORAY from time to time.

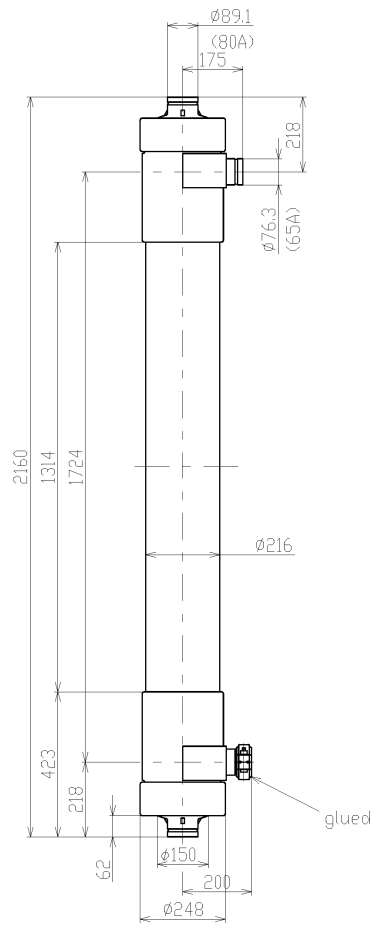

HFU-2020N

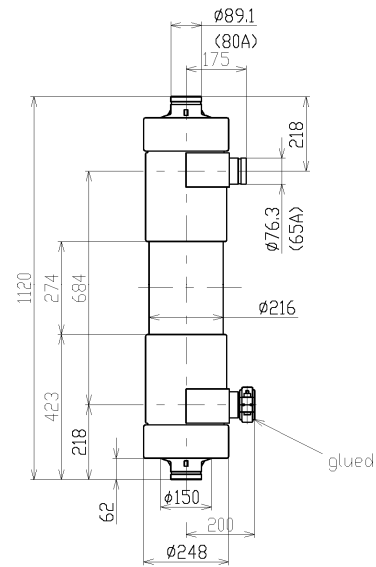

HFU-1020N

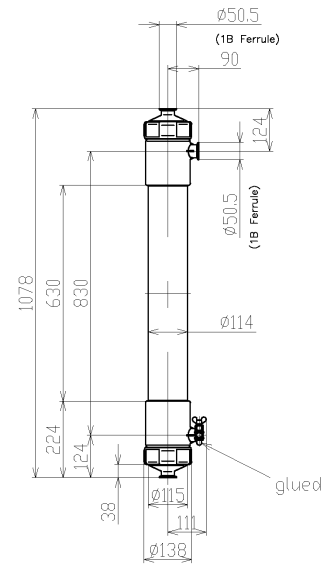

HFU-1010N

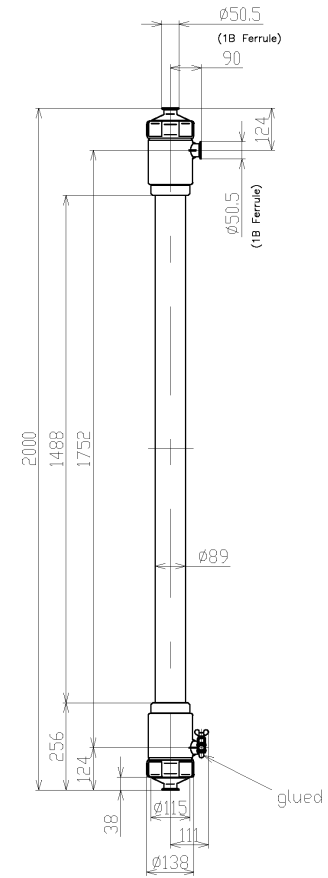

HFU-2008N

Module Configuration